

STANDARD ION AIR KNIFE™ INSTALLATION & MAINTENANCE

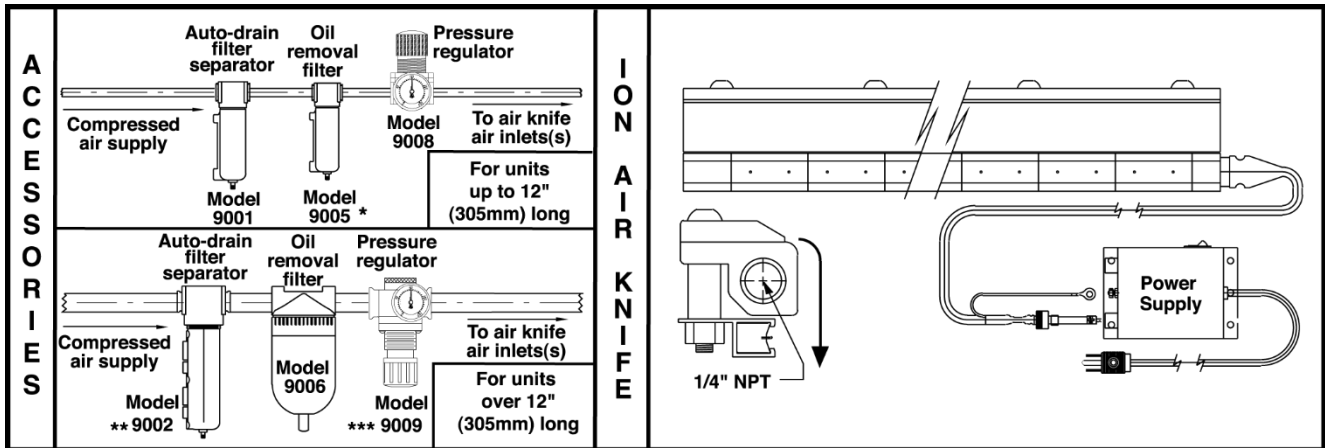

- * Use Model 9006 Oil Removal Filter for Ion Air Knives longer than 6" (152mm)
- ** Use Model 9032 Auto Drain Filter with 18" to 24" (457-610mm) Ion Air Knives
- *** Use Model 9033 Pressure Regulator with 18" to 24" (457-610mm) Ion Air Knives

COMPRESSED AIR LINE SIZES

Compressed air lines should be sized to hold pressure drops to a minimum. Do not use restrictive fittings or undersized lines that can "starve" the Ion Air Knife.

The following chart shows the recommended infeed pipe sizes. If compressed air hose is used, always go one size larger than the recommended pipe size due to the smaller I.D. of hose. (Example: Consider 1/2" I.D. hose the equivalent of 3/8" pipe.)

Ion Air Knife Length	Model Number	Infeed Pipe Size Length of Run		
		10' (3m)	50' (15.2m)	100' (30.5m)
3" (76mm)	7103	1/4"	3/8"	1/2"
6" (152mm)	7106	1/4"	3/8"	1/2"
9" (229mm)	7109	3/8"	1/2"	3/4"
12" (305mm)	7112	3/8"	1/2"	3/4"
18" (457mm)	7118	1/2"	3/4"	1"
24" (610mm)	7124	1/2"	3/4"	1"
30" (762mm)	7130	3/4"	1"	1"
36" (914mm)	7136	3/4"	1"	1-1/4"
42" (1067mm)	7142	1"	1-1/4"	1-1/4"
48" (1219mm)	7148	1"	1-1/4"	1-1/4"

An Ion Air Knife over 18" (457mm) should be supplied with compressed air at both ends.



EXAIR Ion Air Knife is UL Component Recognized to U.S. and Canadian safety standards.



Power supplies are UL Listed to U.S. and Canadian safety standards. There are no user serviceable parts inside.



Power Supplies meet the requirements of applicable European Directive(s).



COMPRESSED AIR SUPPLY

The Standard Ion Air Knife has compressed air inlets on each end. Lengths 24" (610mm) and longer should be supplied at both ends to maintain a balanced airflow. Model 9076 and 9077 Universal Air Knife Plumbing Kits (sold separately) provide the appropriate size hose and fittings for coupling inlets on the same Standard Ion Air Knife.

With proper filtration and separation of dirt, moisture and oil from the compressed air supply, the Ion Air Knife will operate for years without clogging.

Use a 10 micron or smaller filter separator on the compressed air supply. Use Model 9001 Automatic Drain Filter Separator for units up to 12" (305mm), Model 9032 for 18" and 24" (457-610mm) units and Model 9002 for units larger than 24" (610mm). To prevent problems associated with oil, use an oil removal filter. Use Model 9005 Oil Removal Filter for units up to 6" (152mm) and Model 9006 Oil Removal Filter for units longer than 6" (152mm). The oil removal filter should be used downstream from the automatic drain filter separator. Filters should be used close to each Ion Air Knife, within 10 to 15' (3 to 4.6m) is best.

The Ion Air Knife is designed to use normal shop air supplies up to 100 PSIG (6.9 BAR). For infinite control of flow and force, pressure may be regulated. Use Model 9008 Pressure Regulator for lengths up to 12" (305mm), Model 9033 for 18" and 24" (457-610mm) units and Model 9009 Pressure Regulator for lengths over 24" (610mm).

USING THE ION AIR KNIFE

The Model 9060 Universal Air Knife Mounting System (included in deluxe kits or sold separately) can be articulated into any position to provide secure, precise positioning for any air knife. The air knife can also be supported by the compressed air pipe or by using the existing bolts (be sure to re-tighten to 7.5 foot pounds for proper performance).

Connect ground terminal to power supply. Screw power cable into power supply. Upon installation, the ionizer cable should be isolated from grounded metal surfaces by using non-conductive stand-offs/wire ties by at least 1" of air gap. Alternatively, the ionizer cable can be shielded in plastic conduit with dielectric strength equivalent to at least 1" of air (approximately 75kV/inch).

The Ion Air Knife should be located at a point after the material has received its static charge. If the treated material is subjected to additional friction, it may build up another static charge and additional Ion Air Knives may be needed.

The Ion Air Knife should be placed so that the sheet of air flows across the material to be treated. The ionized air will eliminate the static charge from the surface it touches. Mounting the Ion Air Knife close to the surface gives the best static elimination. It may be located above or below the material. When the static charge is extremely high or the material is moving at high speeds, it may be necessary to place an Ion Air Knife on both sides of the material.

The ionizing bar is shockless and may be touched without injury.

The Ion Air Knife and Power Supply Should Not Be Used In An Explosive Or Flammable Area.

ELECTRICAL SUPPLY

The Model 7901 Power Supply (two outlet) and Model 7940 Power Supply (four outlet) require a 115V, 50/60Hz source. The Model 7907 Power Supply (two outlet) and Model 7941 Power Supply (four outlet) require a 230V, 50/60Hz source. For proper operation, the Ion Air Knife and power supply must be properly grounded. If the unit is not grounded, the Ion Air Knife will produce a shock and will not function properly. The ground terminal must be connected to the grounding wire of the Ion Air Knife. A common ground to a machine can be obtained by attaching the metal of the Ion Air Knife and power supply to the metal frame of the machine.

TROUBLESHOOTING & MAINTENANCE

If There Is A Reduction In Flow Or Force From The Ion Air Knife, check the pressure by installing a gauge at the compressed air inlet of the air knife. Large pressure drops are possible due to undersized lines, restrictive fittings and clogged filter elements.

For replacement or repair filter and regulator parts, contact EXAIR at 1-800-903-9247 or techelp@exair.com. Call (513) 671-3322 for outside the US and Canada.

CLEANING

If contaminants have clogged the air knife, inspect the unit by disassembling. The air knife is made up of two component parts, and between them is a shim to set the gap that the compressed air exhausts through. This is usually .002" (.05mm) thick although thicker shims may be used. Inspect each part for dirt contamination and a possible oil film in the area of the slotted nozzle. Clean each part and reassemble with the shim installed in the correct position. Re-tighten bolts to 7.5 ft.lbs. Tighten bolts in sequence starting at one end and working toward the opposite end.

The best method to determine how well the Ion Air Knife is working is with the Model 7905 Static Meter. The static meter is easy to use and will accurately display the charge on a surface without touching it. To do this, simply measure the charge on the surface before ionizing (power supply and air off). Then, ionize the surface (power supply and air on). Measure the surface again. A "zero" volt reading indicates that the Ion Air Knife is working properly. If a charge is still present, this may indicate the need for cleaning.

Keeping the ionizing bar free of moisture and dirt is very important to its effectiveness and life-span. A simple cleaning operation added to your planned maintenance schedule can eliminate potential performance problems. The frequency of cleaning required will depend upon the environment in which the ionizer is installed. Dirty industrial applications may require daily cleaning while clean-room applications may require only monthly cleaning. It is important to evaluate the cleaning needs of each individual ionizer installation.

A soft bristle brush (a toothbrush works well) should be used to clean the emitter points and channel to remove any particulate. Do not use anything that will bend or dull the emitter points. Do not use any soaps or liquid cleaners that will leave a conductive residue. They can destroy the effectiveness of the ionizing bar.

Never Clean An Ionizer With The Power On!

Periodic cleaning will keep your ionizer operating at peak performance for the life of the unit.

COMPRESSED AIR AUSTRALIA PTY LTD

GPO Box 2792, Darwin NT 0801, Australia

Telephone: 1300 787 688

Fax: 1300 787 637

Int'l Telephone: +61 8 8983 3999

Int'l Fax: +61 8 8983 3900

Email: info@caasafety.com.au

Website: www.caasafety.com.au